

The following text is excerpted from chapter 8 of the book
Ferdinand Porsche - Genesis of Genius
By Karl Ludvigsen
Published by **Bentley Publishers**

www.bentleypublishers.com

Permission has been granted by the publisher to the Aircraft Engine Historical Society for display of this excerpt on their website. Additional permission must be requested to reproduce or distribute this excerpt.



B BentleyPublishers™
.com

Automotive Reference™

1734 Massachusetts Avenue
Cambridge, MA 02138 USA
800.423.4595 / 617.547.4170

A new consumer edition of this book will be available in Fall 2009. Please visit our website for more information.

<http://www.bentleypublishers.com/porsche/genesis-of-genius>



of overstatement.” Messrs. Illner and Warchalowski were the fastest overland flyers. Warchalowski reached the highest altitude of 1,500 feet and Illner made the longest flight at three minutes short of two hours. Both height and duration were new Austrian records.

Confirmation, if it were needed, of the merit of Ferdinand Porsche’s new engine came on October 10 when Karl Illner took up the City of Vienna’s challenge of a 20,000-crown prize for a flight from its Simmering Meadow to Horn, 50 miles to the northeast, and return. This went flawlessly, taking 74 minutes for the outbound run and 69 for the return. Illner, in a yellow Etrich *Taube*, set a new Austrian altitude record of 3,300 feet on the way.⁵

Although he missed the start, Porsche arrived at Horn in his Prince Heinrich tourer in good time to supervise the checking of his big four. Back in Vienna, the *Taube* had already landed when the engineer arrived at Simmering to find a crowd still celebrating the feat. Out of it burst the burly figure of Illner, who embraced Porsche with some emotion and said, “Herr Director, I thank you. Your engine made this performance possible. My life depended on its robust operation.” A surprised Porsche was visibly moved

by these unexpected yet sincere plaudits. He and his engine had conquered the new medium of the air, and in style.

Easy to build and safe to fly, Igo Etrich’s *Taube* was the most popular prewar airplane in Germany and Austria. Berlin’s Edmund Rumpler was a prominent German licensee, while in Austria Etrich arranged with none other than Jacob Lohner & Co. to produce his aircraft. To guide his aviation programs Ludwig Lohner engaged an autodidact engineer, Karl Paulal, who had been at Lohner in the Porsche years. In 1901 he’d raced an electric at Semmering and in 1905 he’d accompanied Count Schönborn when he drove his Lohner-Porsche from Vienna to Breslau and back. Under Paulal’s guidance Lohner developed its own swept-wing biplane with Aéro-Daimler power. Lohner also became Austria-Hungary’s leading propeller manufacturer.

Lohner-built *Taubes* were sold and serviced by the Austrian Motor Aircraft Company, entering this new field in addition to its airship projects. As its base for this activity the latter company took over another airplane works on the Wiener Neustadt airfield, complete with some of Etrich’s earliest planes. Skoda’s arrival on

5. An obelisk memorializing this flight still stands in Horn.

the scene led to a restructuring of the company in 1915 as the Austrian Aircraft Factory AG or ÖFFAG as its acronym.⁶ Both Karel von Skoda and Ferdinand Porsche had shares in the firm, which was managed by Karl Ockermüller.

Advances in aircraft design during World War I were so rapid that the *Taube* was soon outdated as a combat plane but was still valuable in a reconnaissance role. It had one signal military achievement to its credit. Several Aëro-Daimler-powered *Taubes* were sold to Italy, which in September 1911 opened hostilities with Turkey over its African holdings. Turkish troops at an oasis in Libya, then Tripolitania, were startled on November 1 to see and hear a *Taube* overhead. They were even more discomfited when its pilot, Lieutenant Gavotti, dropped four 2-kilogram grenades

in their midst. Further raids followed this, history's first aerial bombing in wartime.

Ferdinand Porsche's next step would take him into aviation's hall of fame. Responding to the obvious need for higher power in aero engines, he added two cylinders to his four to produce a six. Several engines of exactly this type were built, with the same cylinder dimensions as the big four to give 9,500 cc and 90 bhp at 1,300 rpm. This was a step along the road to Porsche's larger six, which was ready astonishingly quickly, in 1911. Its dimensions were 130 x 175 mm for 13,937 cc. The 419-pound big six's initial output of 120 bhp at 1,200 rpm was soon raised to 130 bhp.

6. The Österreichische Flugzeugfabrik AG.



All aspects of its construction were akin to those of the successful four. For greater stiffness to suppress torsional vibration the crankshaft's bearings were enlarged to 45 mm, with hollow journals for lightness. Connecting rods were 300 mm long. Bevel gears at the back end of the crankshaft drove two magnetos at the sides, a water pump at the bottom and, at the top, the Friedmann oiler. The latter had a new task, which was to meter oil to the bottom of each bore on the thrust side of the piston. Gradually

introduced at Wiener Neustadt were less-time-consuming techniques for forming the water jackets from thin sheet-metal fabrications, initially copper and later steel.

Still exposed at the top of the cylinders, the single-rocker valve gear was unchanged in principle. Though a disadvantage of the design was that no overlap could occur at top dead center between exhaust-valve closing and inlet opening, the generous apertures of the 65 mm valves gave ample gas flow. Front and rear



trios of cylinders were fed by separate manifolds, each with its own updraft carburetor. As with the fours, coolant flow in and out of the cylinders was concentrated on the exhaust side.

Experts in the field endow this Austro-Daimler six with landmark status. “Reliable and efficient,” wrote Bill Gunston, “these engines are generally regarded as the inspiration—some have said the prototypes—of the many thousands of engines made for the German and Austro-Hungarian aircraft during the war,

by Mercedes, Benz, BMW, Hiero and others. From the start the modest rpm and general stress levels resulted in good reliability.”

Another aviation historian, Herschel Smith, said, “At the outbreak of the First World War the world’s most efficient and reliable aircraft engine was the 120-hp Austro-Daimler. This water-cooled in-line six, the work of Dr. Ferdinand Porsche, was the prototype of all the Central Powers wartime engines and of many built elsewhere.” In the latter category were the engines produced

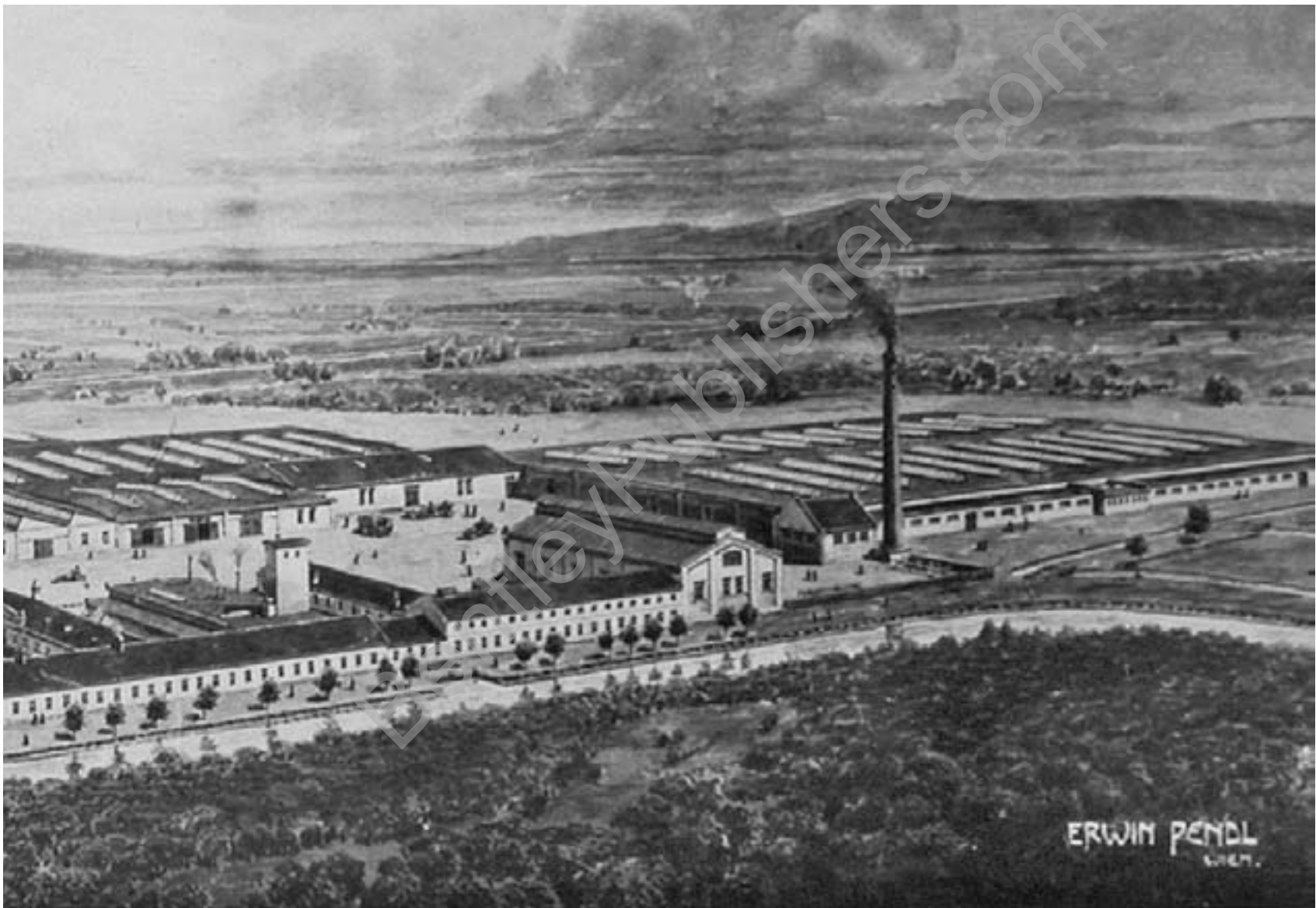

ABOVE: A 1909 view of the Austro-Daimler works at Wiener Neustadt showed its propinquity to the open Steinfeld that nurtured the Dual Monarchy’s aviation industry. The smoking chimney in the foreground marks Porsche’s villa on the Pottendorferstrasse.

FACING PAGE: *An unfortunate landing in 1911 by a Lohner-built Etrich Taube showed the elegant lines of its wings, which were inspired by the shape and aerodynamics of the zannonia seed. To improve landing stability on rough surfaces the craft were given four wheels instead of two.*

BELOW: *The Etrich Taube marked the beginning of heavier-than-air flight in Austria. Its graceful lines and benign control characteristics led to its wide use as a trainer not only in Austria but also in Germany, where replicas were built by Edmund Rumpler.*



in Scotland by Arroll-Johnston to be sold by Beardmore. These brought welcome licensing income to Wiener Neustadt, whose engineers journeyed to Britain's north to help the Scots master the production techniques.

Early notoriety came to the six thanks to the activity in Britain of Samuel Franklin Cody, an American who made the first flight in the United Kingdom with a self-built aircraft in 1908.⁷ Cody was on his third airplane, already much rebuilt, in August 1912 when the British military staged trials on Salisbury Plain of

potential designs for the Royal Flying Corps. In search of more power for a biplane that others called "an obsolete monstrosity," Cody had obtained a six-cylinder Austro-Daimler in April 1911. In the trials, said Bill Gunston, "its completely reliable 120 hp carried all before it" and won for the American the £5,000 first

⁷ Cody didn't discourage those who thought he was related to the famous Buffalo Bill Cody, but in fact his name was originally Cowdery. He changed it in honor of his boyhood hero.



prize.⁸ The size of that award may be appreciated in relation to the price of the engine, which was £850.

Porsche's six also showed its mettle in flights to high altitudes. In 1913 the height of 16,436 feet was reached in a Lohner aircraft with two passengers. At Leipzig in the following year the world's altitude record was unofficially surpassed by Oelrich in a flight to 24,800 feet in an all-metal DFW biplane—still with the nominal 120 bhp engine.

The Austro-Daimler six's merit was underlined by the use of two such engines late in 1915 to power the Pemberton-Billing P.B.29E. This was an extraordinary quadruplane—four wings stacked from top to bottom—intended to patrol the British skies in search of German airships during the war. It carried a searchlight and machine guns to mow down the dirigibles that were being used for bombing missions over England. That a British company

would use engines made by its battlefield enemies testified to their excellence.

At the outbreak of war, in response to demands from the military for still more power, Ferdinand Porsche produced an uprated version of his six-pushrod engine that was credited with up to 165 horsepower. It was short-lived, however, for in parallel the engineer had a completely new engine on the stocks. As a few other aero-engine producers had hinted, including Mercedes in 1912, an overhead camshaft was the next step forward to gain higher performance with reliability.

8. This was much to the credit of Porsche's engine. However, Cody's "weird biplane" was in fact outperformed in the trials by a government-built aircraft, not eligible to compete, piloted by Geoffrey de Havilland. His was the design that ultimately prevailed.

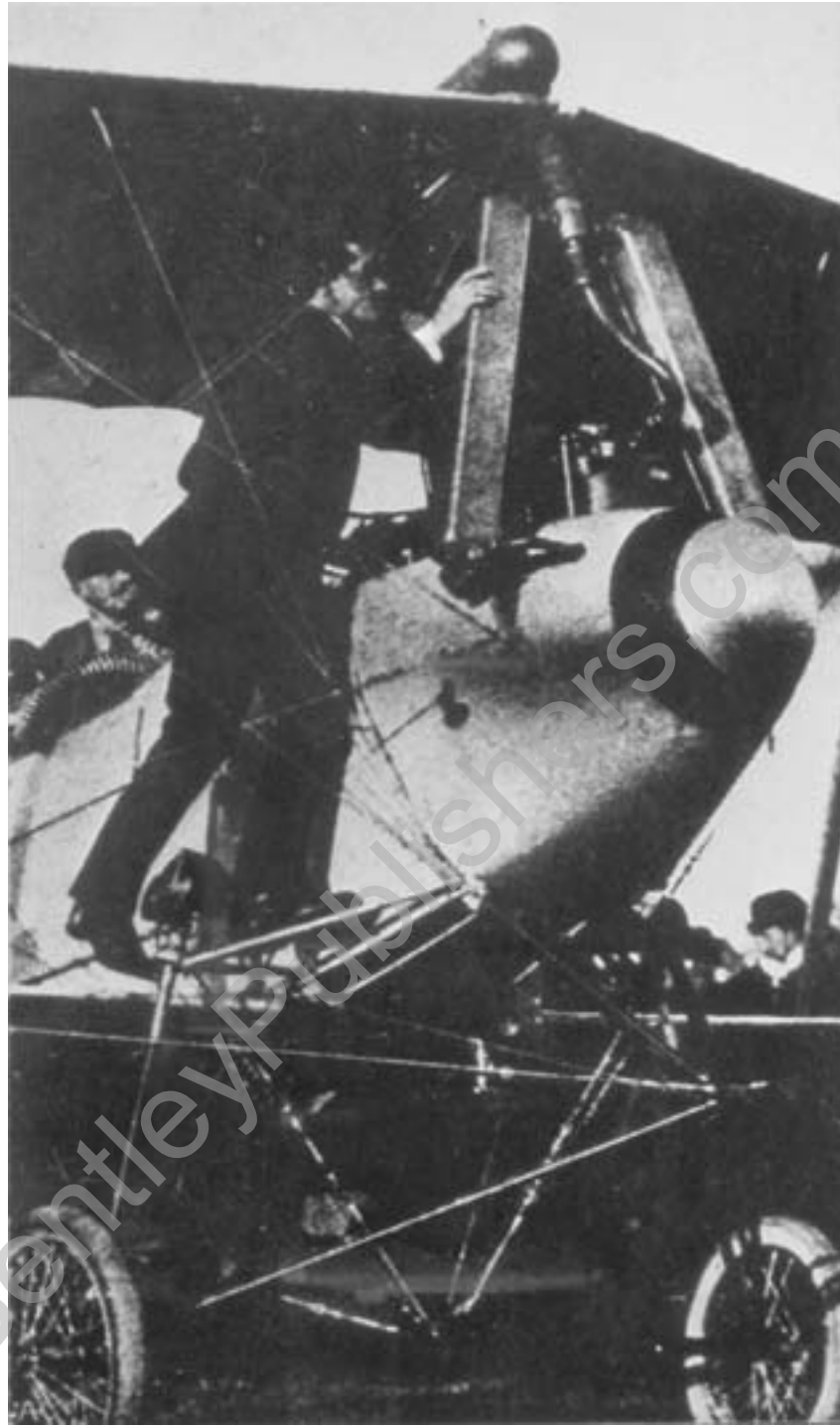

Ready for production in the second half of 1915 was Porsche's first overhead-cam aero engine.⁹ From his Prince Heinrich design he reverted to conventional rocker arms from a single overhead camshaft, driven by a vertical shaft and bevel gears at the six's propeller end. Two valves per cylinder were closed by coil springs. Instead of iron, the new engine had cylinders of cast steel. Pistons were aluminum initially, but later cast steel was used. For compatibility with the cylinder bores this required coating the pistons with white metal or aluminum. Porsche relinquished the *désaxe*

cylinder in favor of conventional alignment. Gone was the faithful Friedmann oiler, supplanted by recirculating lubrication with a reciprocating pump below the bevel drive.

Twin magnetos were at the front of the overhead-cam six while the water pump was at the rear. Induction was now through a single twin-throat updraft carburetor, simplifying adjustment, on

9. Although it made flights in the *Möwe*, the overhead-cam Prince Heinrich four was not designed as an aero engine.

the left side. Measuring 135 x 175 mm for 15,030 cc, the new six initially developed 160 bhp at 1,300 rpm. With a higher compression and 1,400 rpm the 660-pound unit was persuaded to 185 bhp in 1916 and ultimately to 200 bhp at 1,500 rpm.

At the request of the navy, in 1915 Ferdinand Porsche and his team used their six's cylinders to create their first-ever vee-twelve. Displacement was doubled thereby to 30,059 cc in a handsome 1,025-pound engine that produced as much as 382 bhp at 1,500 rpm. Initially fork-and-blade connecting rods were used, but these weren't kind to their bearings so the bottom end was changed to master rods on the right side and link rods on the left. Induction pipes in the central vee drew mixture from two double-throat carburetors on the left side of the engine in passages through the crankcase that cooled engine oil and gently warmed the fresh mixture. Porsche was granted a patent on this innovation.

The zenith of Austro-Daimler's aviation sixes was attained in 1917 with the introduction of a new engine of 140 x 175 mm for 16,164 cc. Its basic layout was derived from that of the 15-liter six with the major change of four valves per cylinder. Each rocker arm was forked at the end to open paired 44 mm valves. Ram air was channeled from front to back of the sump to provide oil cooling. With aluminum pistons, this six delivered 225 bhp at 1,400 rpm. Like all other production aero engines from Wiener Neustadt, it passed a 100-hour full-power test.

The last Austro-Daimler aero engine to enter volume production during the war, this 24-valve engine saw service in a number of Central Powers aircraft. To augment Wiener Neustadt's capacity it was also made in Munich under license by Karl Rapp, whose company was a predecessor of BMW. In 1918 Austro-Daimler was working on a bigger-bore version of 18,555 cc (150 x 175 mm).

№r. 21 Allgemeine Automobil-Zeitung. Seite 33

AUSTRO
DAIMLER
WIENER NEUSTADT
Benzinmotorwagen

:: Sieger der Prinz Heinrich-Fahrt 1910 ::
Sieger der Non-Stop-Fahrt London-Edinburgh 1911

9,20HP Kardan 9,27HP Kardan „Type Alpenwagen“
18,36HP Kardan oder Kette 27,60HP Kardan

AËRO-DAIMLER
Flugmotoren

Die **3 ersten** im
Ueberlandflug Wr.-Neustadt – Oedenburg – Wr.-Neustadt.
 Sämtliche österreichischen Rekorde, darunter auch der

Höhenrekord
werden von „AËro-Daimler“-Flugmotoren gehalten.

Inhaber des Passagier-Welthöhenrekordes:
Leutnant von Thyna auf „Etrich-Rumpler“ mit 65/70HP „AËro-Daimler“
35/40HP 65/70HP 120HP

Oesterr. Daimler-Motoren-A.-G.
Wiener-Neustadt
Verkaufsbureau: Wien, I. Schwarzenbergstrasse Nr. 2.

LEFT: The achievements of Aëro-Daimler figured large in an advertisement from Wiener Neustadt that also boasted of the company's 1910 Prince Heinrich success. Aviation promised to be an important new earnings generator for Austro-Daimler.

FACING PAGE (top): Ferdinand Porsche's 13.9-liter six of 1911 was a landmark prime mover in his career and in the development of aviation power. Viewed here on its inlet side, it had twin updraft carburetors and a single camshaft operating push-and-pull rods from innovative desmodromic tappets.

FACING PAGE (bottom): A lateral section of the Austro-Daimler six of 1911 showed its désaxe cylinder alignment and leaf spring closing both valves, improved in function from the Fiat example. Its initial output of 120 bhp was soon uprated to 130 bhp.

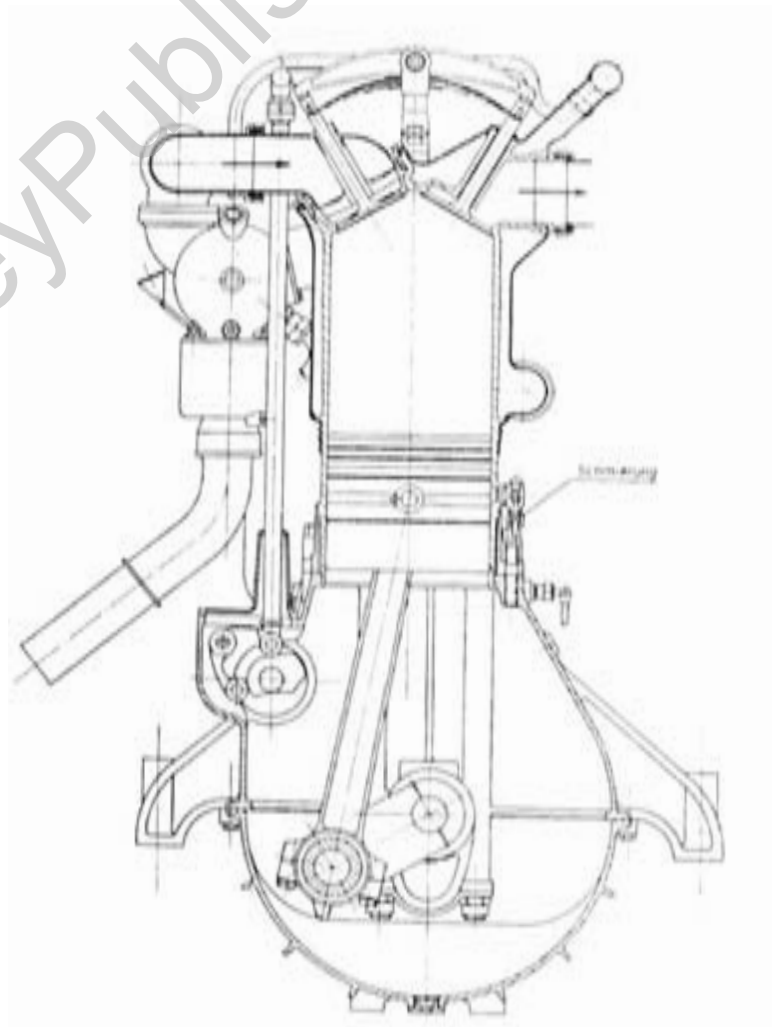
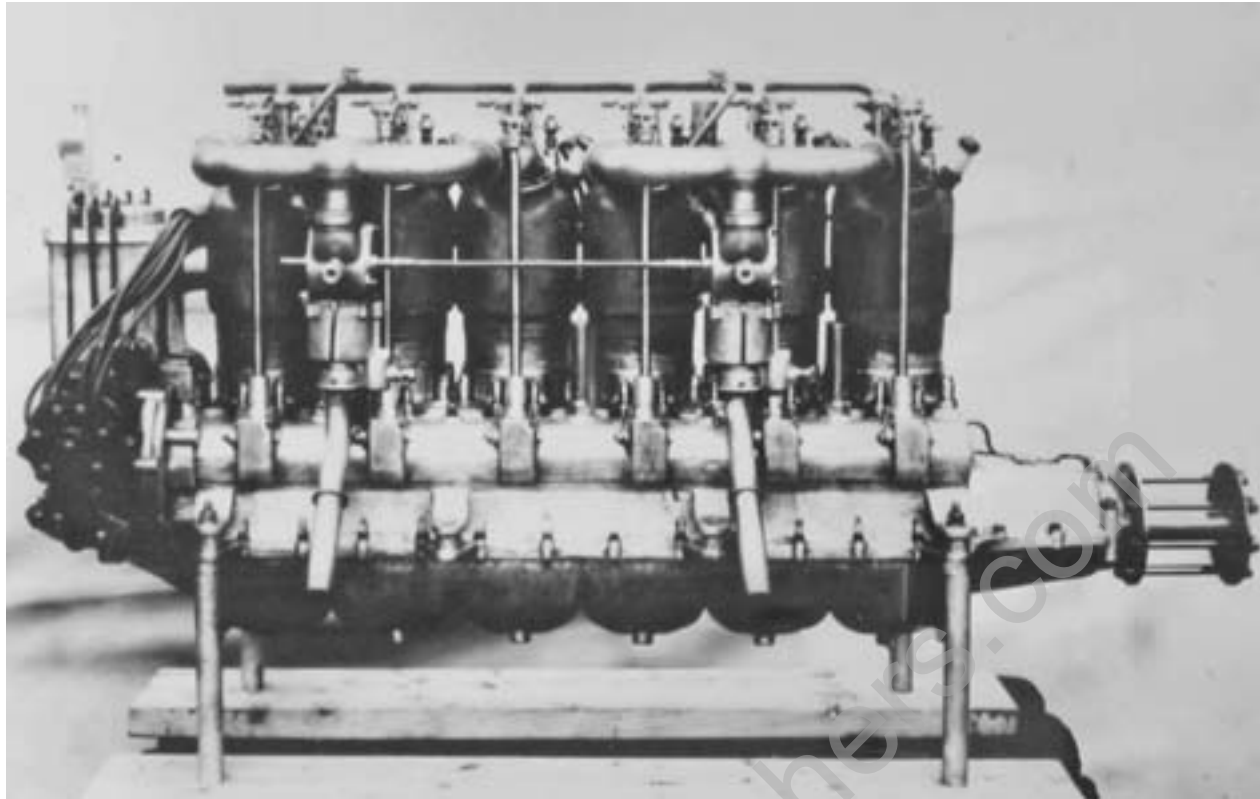



Significantly lightened as well, this saw as much as 280 bhp at 1,400 rpm in tests but was never released for production. Neither was a high-compression version designed to be throttled at sea level so that it could produce its best power in the thinner air of high altitude.

By the time this engine was introduced, many other sixes were in the field from manufacturers on both sides of the conflict. But as the experts testified, Porsche had been there early. Extrapolating a four to a six was no easy matter, as pioneers discovered. The torsional vibrations of its crankshaft defeated many. But Porsche and his team

had shown that it could be done, at first with their 120-horsepower six and later with developed versions. This was a signal contribution to the evolution of the aviation engine and the airplane.

THE LAST 18 MONTHS of the war found Ferdinand Porsche and his colleagues at work on all-new engines of even higher power. They made a single-cylinder test engine measuring 180 x 250 mm, which as a six would have displaced a massive 38 liters. Chief tester Otto Zadnik reported that it gave the best specific torque

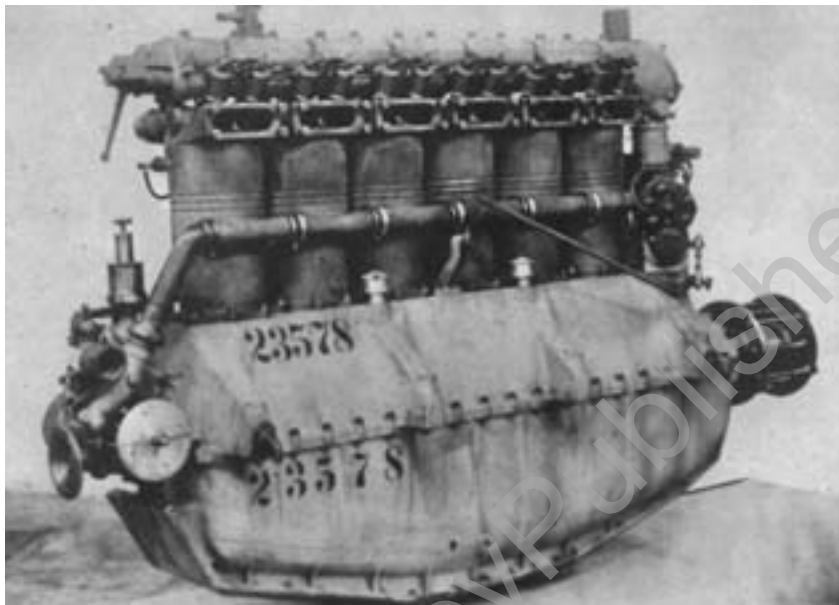

THIS PAGE: *Austro-Daimler's 24-valve six of 1917 had twin magnetos driven from the vertical king shaft at the front. Its rear-mounted water pump delivered coolant to the individual cylinders through a manifold on the right-hand or exhaust side.*

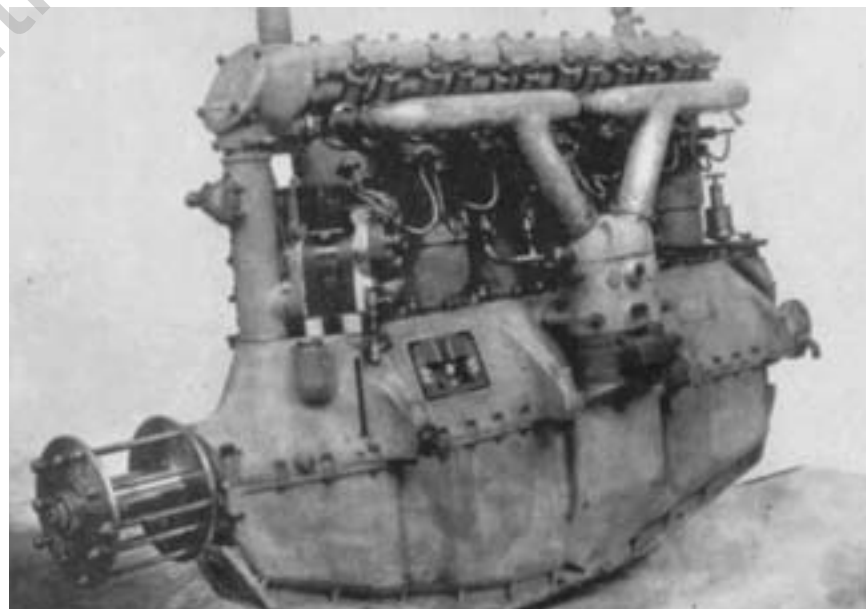

that Porsche had yet achieved in an aero engine. It would have approached 600 bhp at 1,400 rpm in a full power unit.

Equipped to allow trials of different spark-plug positions, the single-cylinder engine had two inlet valves and three exhaust valves for better cooling. Finding the triple exhausts unreliable, Porsche reverted to a four-valve head for a six based on these tests. With square dimensions of 180 x 180 mm for 27,483 cc, it produced as much as 360 bhp at 1,400 rpm. Though this was made in a small preseries it never reached the front lines.

Also interrupted by the 1918 armistice was Porsche's work on another aero engine, his most advanced and ambitious. Called the

RBI, it was a W9. Its three banks of three cylinders radiated from the crankshaft centerline with 40 degrees between them. Each trio of cylinders was fabricated of steel as a single block. This was done by welding together sets of preformed components in a process, patented by Porsche, that would allow high-volume production at low cost. Although the first such engine was a nine-cylinder, Porsche saw it as a concept that could easily be scaled up to more triple-cylinder multiples.

Each cylinder bank had a single shaft-driven overhead cam. This operated four vertical valves per cylinder in a unique manner. Instead of being paired at the sides of each cylinder, the

FACING PAGE (top): By 1917, when this lineup of 225 PS engines was pictured, the new assembly halls at Wiener Neustadt were meeting the demands of the Central Powers for aero engines as well as the other war materiel they were manufacturing.

FACING PAGE (bottom): Used in a number of Central Powers aircraft, the versatile 225 PS Austro-Daimler six was also produced in Munich by Karl Rapp under license. An 18.6-liter version was built but not placed in production before the armistice.

THIS PAGE: When the war ended Porsche was working on this 27.5-liter six with square dimensions of 180 x 180 mm. After single-cylinder trials of five-valve heads he reverted to four valves and sophisticated inlet manifolding to produce its 360 bhp at 1,400 rpm. Only a pre-series was produced.

FOLLOWING PAGE: Three of the pre-series 360 PS Austro-Daimler sixes were suspended between the wings of this flying boat, seen in the halls of ÖFFAG at Wiener Neustadt in 1918. Intended for reconnaissance duties, it was commissioned by the Royal Austrian Navy.

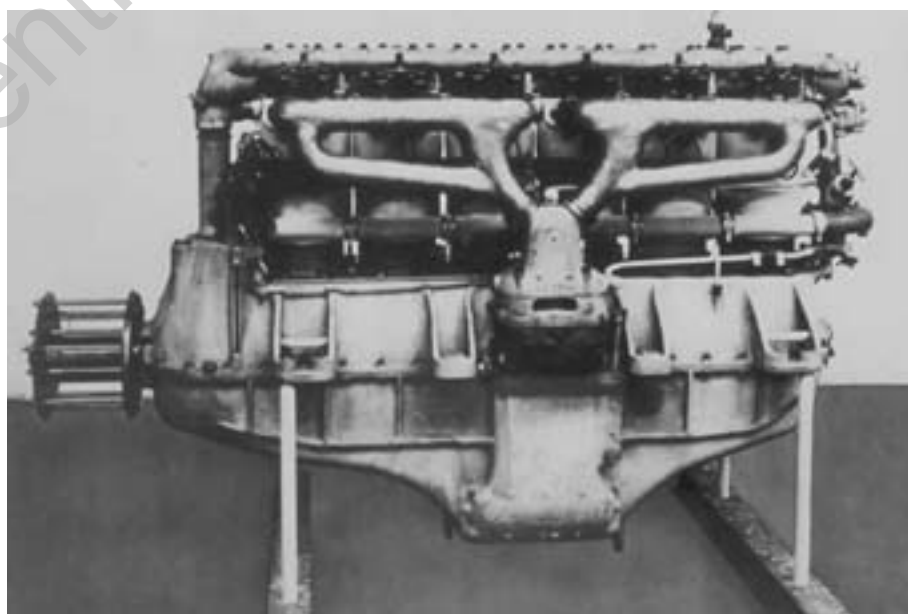
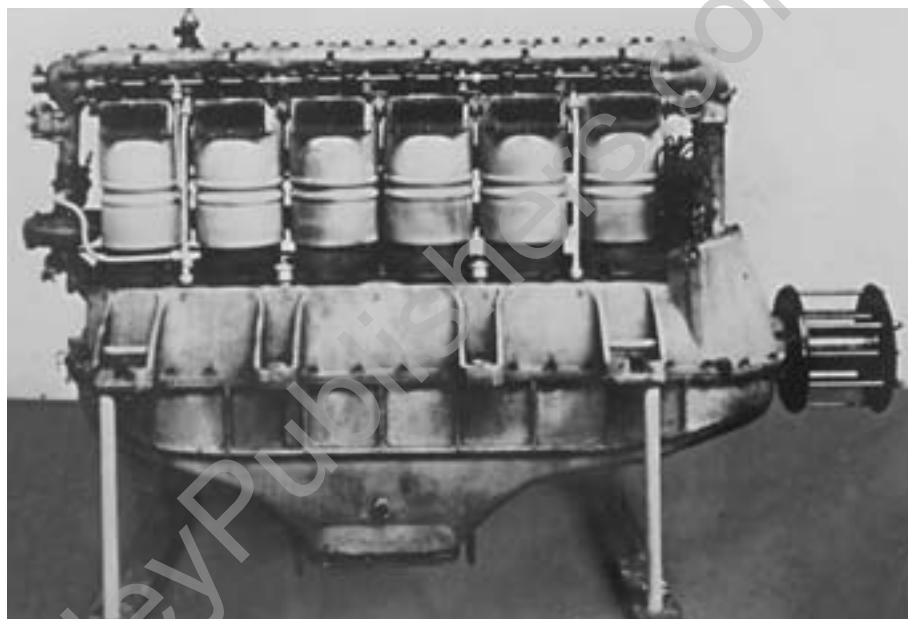

pairing was across the cylinder. Above both valves Porsche placed a rocking beam with a central pivot. At this pivot was a roller contacting the cam lobe. Holding the pivot were the prongs of a stirrup that was hinged to the cylinder head. When the cam lobe pressed the roller and pivot down, the rocking beam opened both valves at the same time, guided by the stirrup.¹⁰

Ferdinand Porsche solved the knotty problem of the triple-bank nine's bottom end by giving master connecting rods to the central cylinder bank and link rods to the two outer banks. Massive four-bolt caps held the main bearings of its counterbalanced crankshaft. Balancing the W9's bottom end was important, for this 105 x 140 mm (10,910 cc) engine was designed to produce

power through speed, not capacity. It was to run at 3,000 rpm, twice the usual rate, and to have its output geared down to 1,500 rpm to suit available propellers. Compact and light, the RBI was producing 300 bhp when the armistice was declared.

Yet another experimental aero engine, dated to 1912–13, is the most enigmatic of this era. Its four cylinders had the exceptionally long-stroke proportions of 120 x 220 mm for 9,953 cc.

10. Porsche obtained a patent on this valve gear. It included an important refinement. For this to work, both valves had to be in position. If one were stuck open—a not-unknown occurrence—the balance beam wouldn't open its neighbor. Porsche built limit stops into the stirrup that would catch the balance bar, and hold it in place, if this happened.

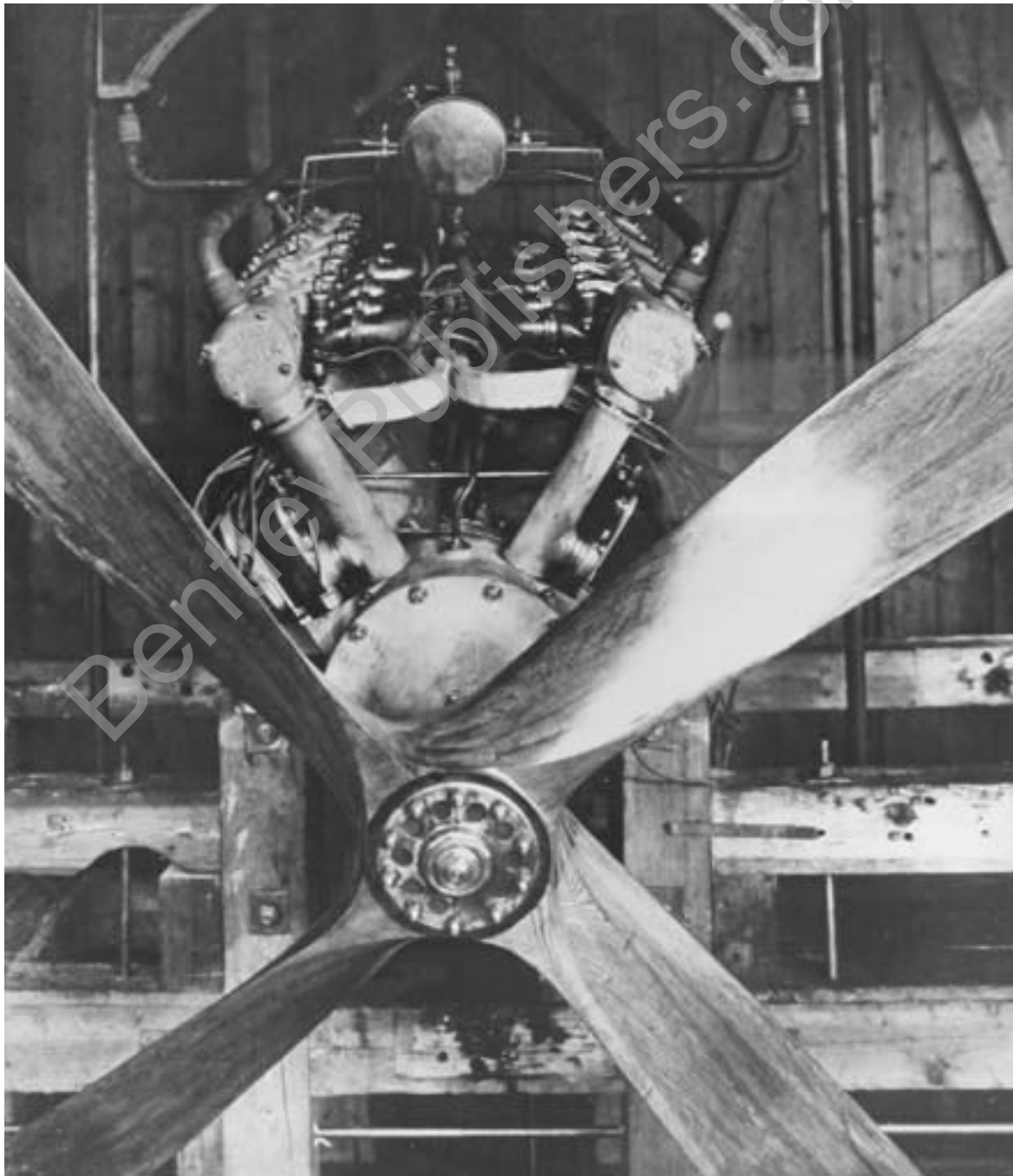

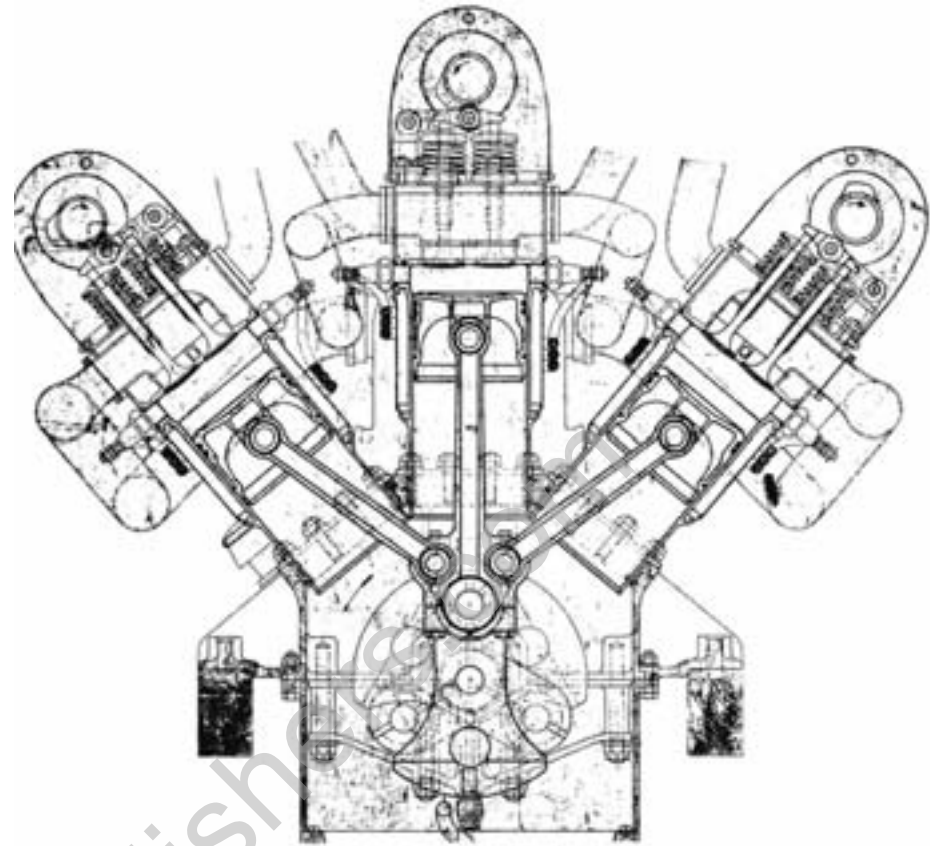
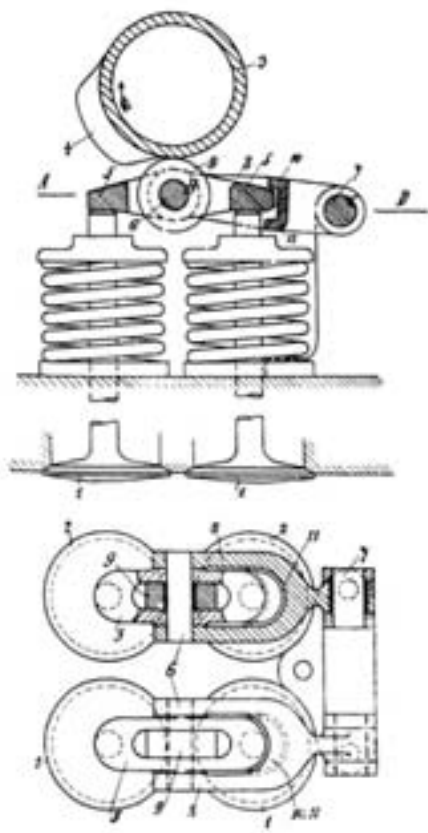

ABOVE (right): An end view of the "broad arrow" Type RBI showed its central master connecting rod, 40-degree angle between cylinder banks and cylinder components designed by Porsche to be capable of volume production. Each bank had a single shaft-driven overhead camshaft.

ABOVE (left): Porsche patented the innovative valve gear of his Type RBI aero engine, which had four-valve heads with their paired valves placed athwart the head instead of longitudinally as usual. A single cam lobe opened both valves simultaneously by working against a rocker pivoted within a swinging stirrup.

RIGHT: This exceptionally novel W9 was under development at the end of hostilities, envisioned as the precursor of engines with more multiples of its basic three-cylinder "trident" module. Porsche planned to gear the propeller down from the 3,000 rpm speed at which this 10.9-liter Type RBI developed 300 bhp.

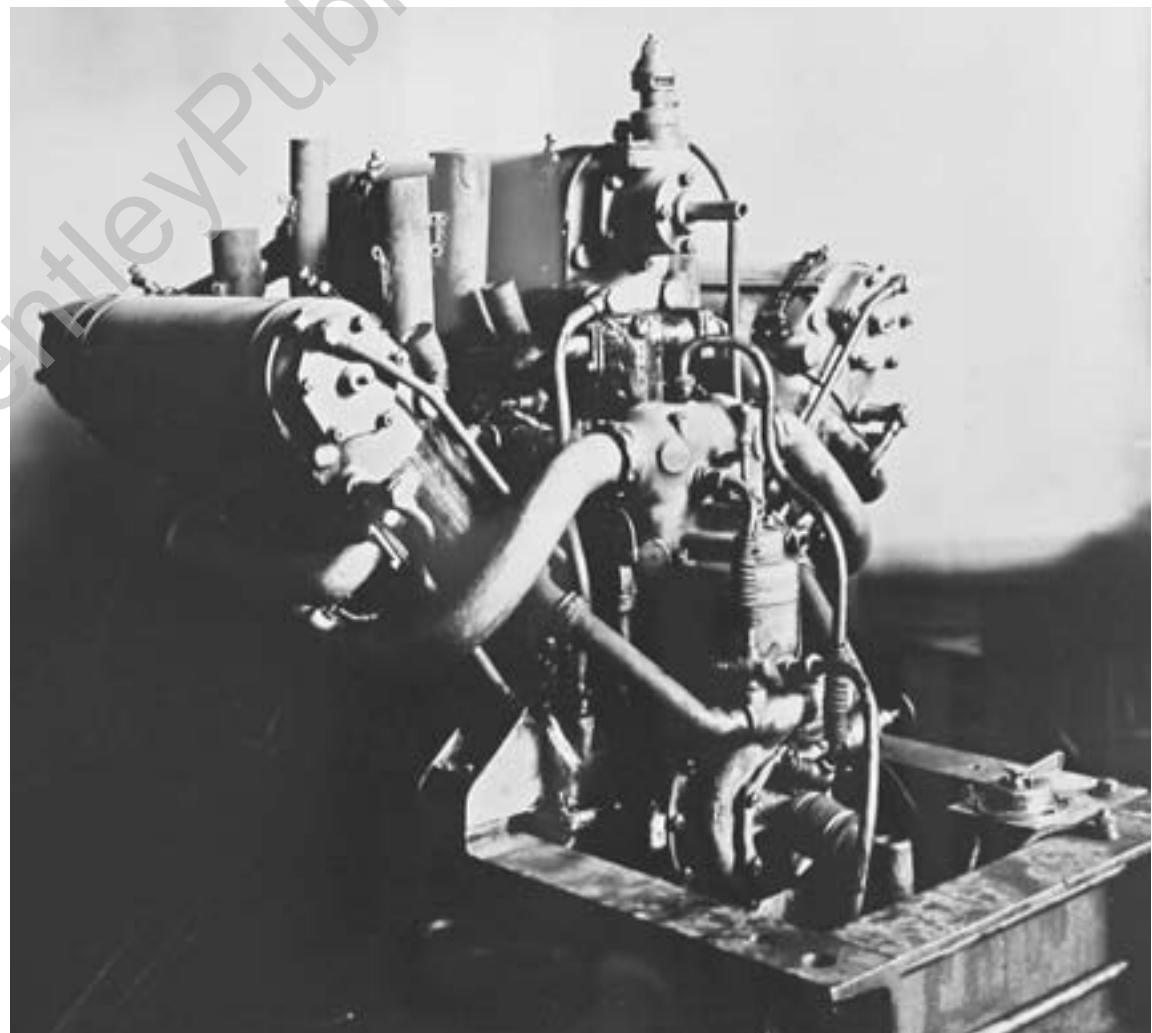

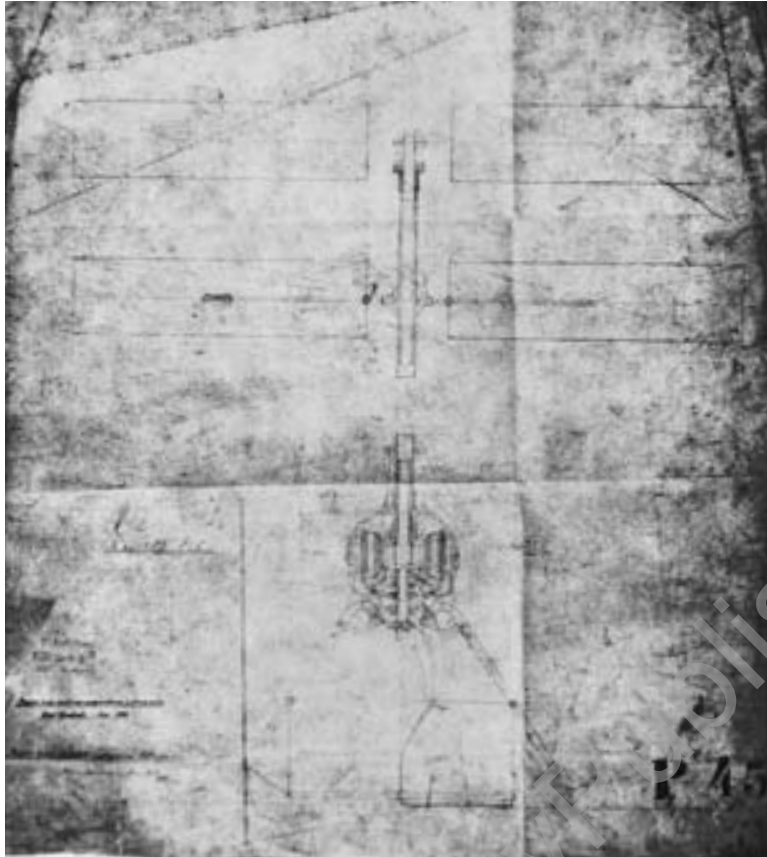

LEFT: Ferdinand Porsche's electrical know-how was put to its ultimate test before the war in the design of an aerial observation platform held aloft by rotor blades powered by a motor that received current from a ground-based supply through a cable. Drawings prepared for Austro-Daimler's project P451 in 1908 showed its electric motor and counter-rotating blades. Its platform was to carry an observer with field glasses.

ABOVE: The cover of a 1919 issue of AAZ depicted the rotor blades of the aerial observation platform being developed late in the war by Porsche with Lieutenant Stephan von Petroczy. It was to have a 300-horsepower electric motor weighing no more than 550 pounds to power its rotors. In spite of the engineer's best efforts this proved to be beyond the state of the art of 1918.

This was even more capacity than Porsche's 90-horsepower six of 1911. Air-cooled with very fine finning, its cylinders had Porsche's single-rod control of overhead valves.

In an extremely unusual layout, the four's cylinders were horizontally disposed as two 20-degree vees, opposite each other, on a common crankshaft. Ancillaries were typical of the period with a Friedmann oiler, twin magnetos and a single central carburetor feeding both cylinder pairs through long pipes. No information has come down to us about the performance of this engine or the reason for its construction. It has all the earmarks of a unit built by Wiener Neustadt to the unusual requirements of a particular customer.¹¹

Ferdinand Porsche's restless creativity attained an apotheosis in two more aviation concepts worked out before and during the war. One applied his Mixte concept to aircraft. It would use the same basic high-speed rotating components for both generator and motors. This would allow a single gasoline engine, powering the

dynamo, to drive several propellers placed wherever the airframe designer desired. Porsche worked out, and patented, a way to use both the engine's inlet suction and the available airflow to cool the electrical machinery.

The other aeronautical concept traced its origins to 1908 when, as project P451, Austro-Daimler first explored the idea of an electrically powered tethered helicopter as an artillery observation platform. Balloons and kites had been tried for this purpose, with obvious disadvantages. Why not, thought Porsche, use electric power to support a platform? A drawing of 1908 shows a wheeled platform underneath an electric motor, which drove counter-rotating blades. Power was to be fed to the motor by a

11. Rewriters of history, eager to trace the history of the Volkswagen back to 1913, have described this as a "boxer" engine, i.e., as a horizontal four. This it is emphatically not. It is a peculiar form of radial engine about whose bottom-end design we can only conjecture. So alien is it to the thrust of Porsche's work that it is difficult to credit its configuration to him.

cable from the ground to lift a unit weighing 400 pounds to an altitude of 330 feet.¹²

The idea simmered until the outbreak of hostilities. Then in 1915 the army's Lieutenant Stephan von Petroczy brought it up again. He and Porsche decided to tackle the challenge using internal-combustion power. Austro-Daimler undertook to supply an engine producing 200 horsepower that weighed no more than 550 pounds. This was within shouting distance of a lightened version of Porsche's first overhead-camshaft six. The project found neither backing nor priority over Wiener Neustadt's other tasks at that time.

Von Petroczy wasn't easily discouraged. He revived his idea in the last months of the war. Electricity was back on his agenda, thanks to Ferdinand Porsche's commitment to produce a motor able to generate 300 horsepower at a speed of 6,000 rpm, geared down to 1,000 to drive the rotors. It was to weigh only 550 pounds as part of a complete apparatus which, with observer, machine gun and power cable would scale 2,650 pounds. While Austro-Daimler would build the motor, ÖFFAG would produce the airframe and rotors.

Even with his ideas for cooling it, such a motor proved beyond Porsche's capabilities. Overheating meant that he couldn't maintain its rated speed and power. Problems with poor rotor performance also hampered the project's progress. To the rescue came a Budapest-born scientist who in 1912 had founded an aerodynamics institute at Aachen. During the war Theodor von Kármán was serving ÖFFAG as the chief of its experimental

department at Fischamend. He and his colleagues succeeded in vastly improving rotor efficiency. After model trials a full-scale vehicle was built using three Le Rhône engines. Tethered flights to more than 150 feet were made before engine failure caused a crash that ended the project.

The crossing of paths of von Kármán and Porsche was historic. While Porsche remained loyal to his homeland, almost to a fault, Theodor von Kármán would move to California in 1930 and become an American citizen in 1936. Six years younger than Porsche, von Kármán would build a brilliant career as a pioneer aerodynamicist of the jet and rocket age.

Ferdinand Porsche did not enjoy von Kármán's freedom. With the capitulation of Austria-Hungary he was in sole charge of an enterprise on which thousands in the surrounding countryside depended. Its military market had collapsed and its home market had all but disappeared. All Austro-Daimler had to offer the world was a celebrated reputation for outstandingly creative engineering and meticulous manufacturing on land and in the air. That would have to suffice for a new beginning.

12. At the request of Chislaine Kaes, a Porsche engineer assessed this design in 1968. He estimated that with 1908 technology its motor would produce no more than 5 horsepower. "Based on this power," the engineer said, "and on the basis of its own weight and that of the necessary cable, it's practically impossible to lift it to the desired altitude, quite apart from the size and position of the rotors and the speed developed by the motor."