

4

3

2

1

D

D

C

C

B

B

A

A

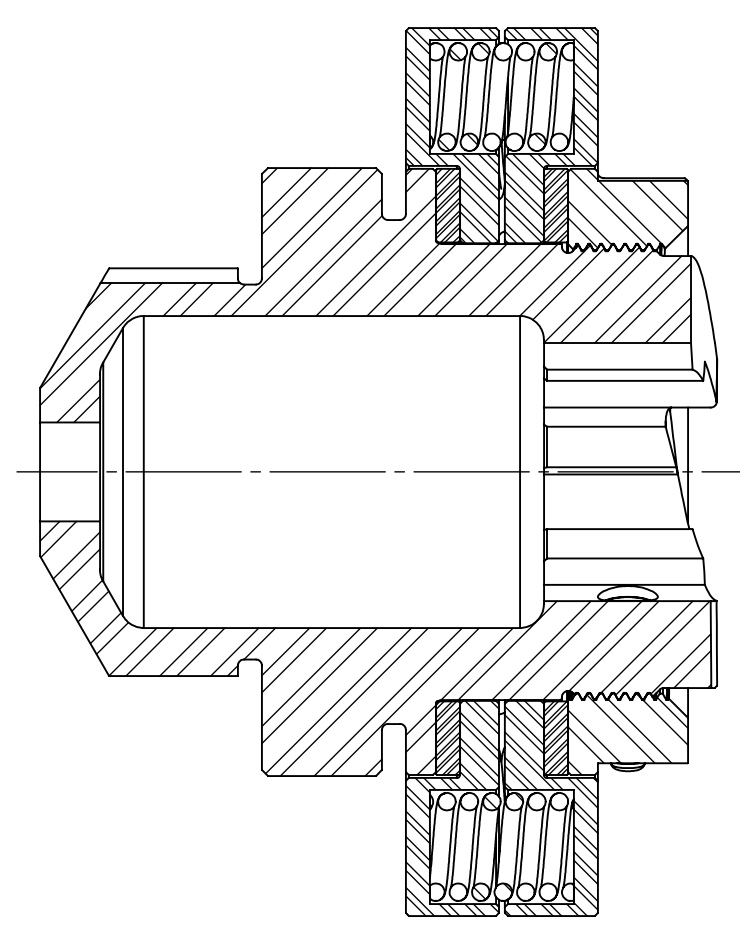
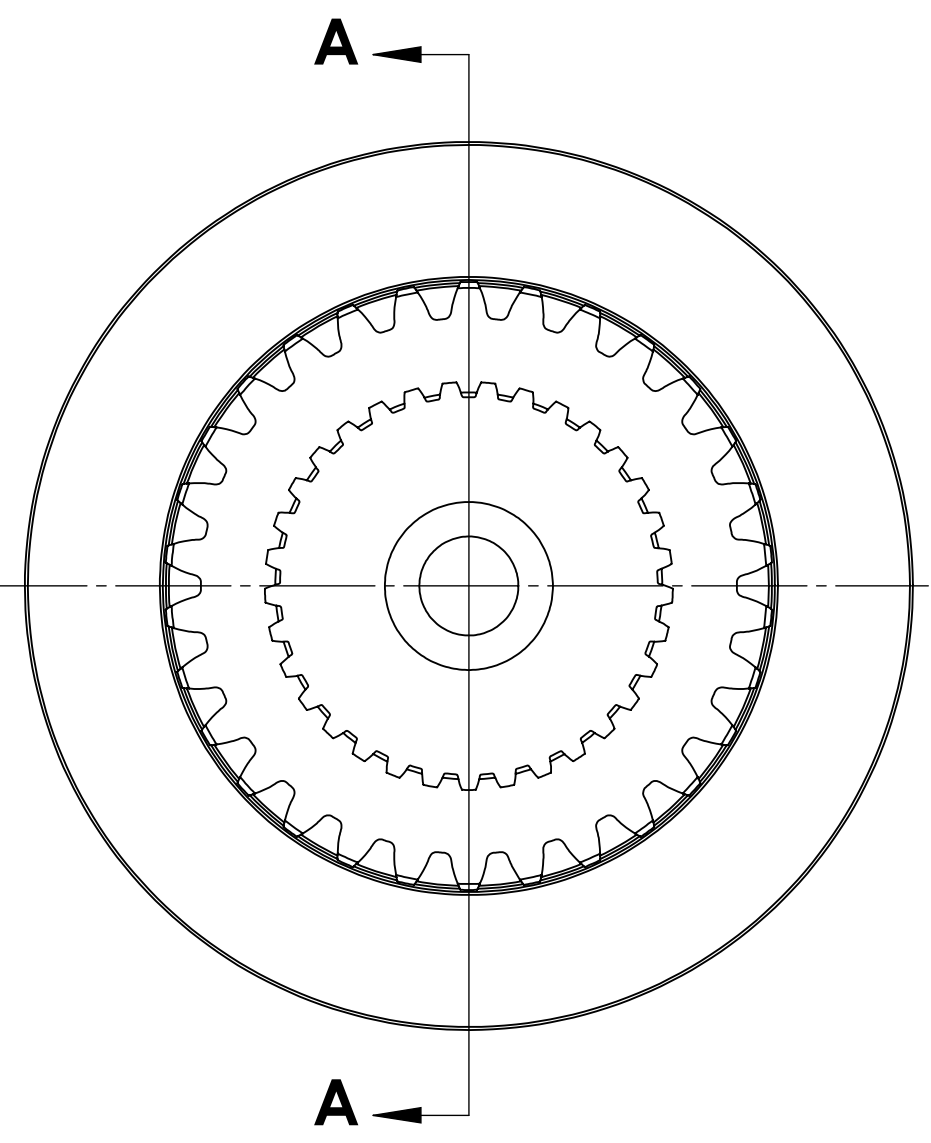

SECTION A-A

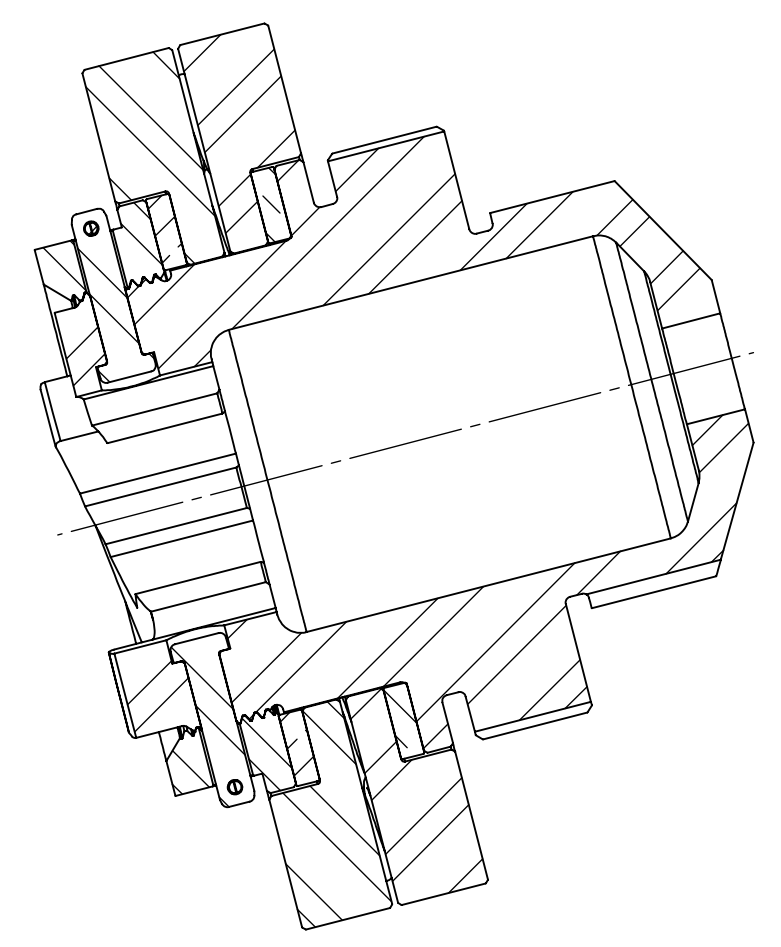
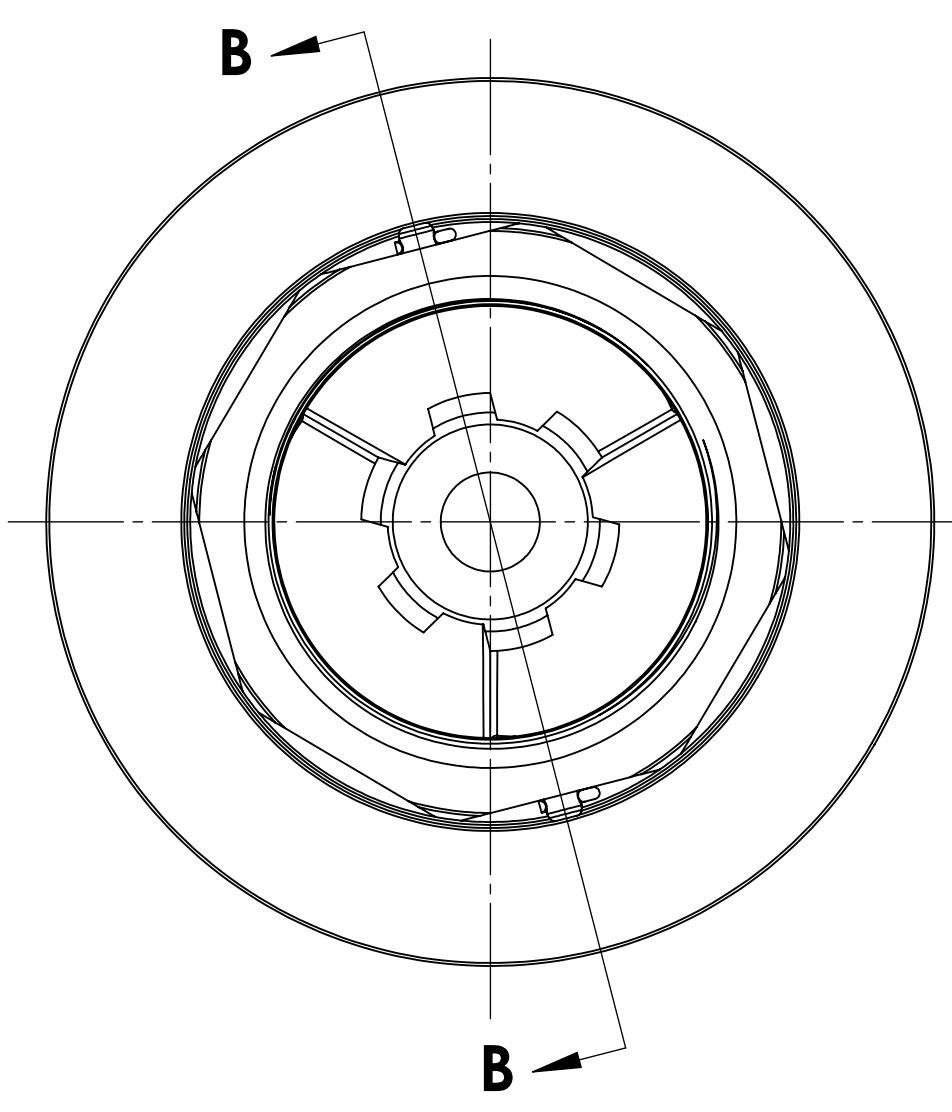

SECTION B-B

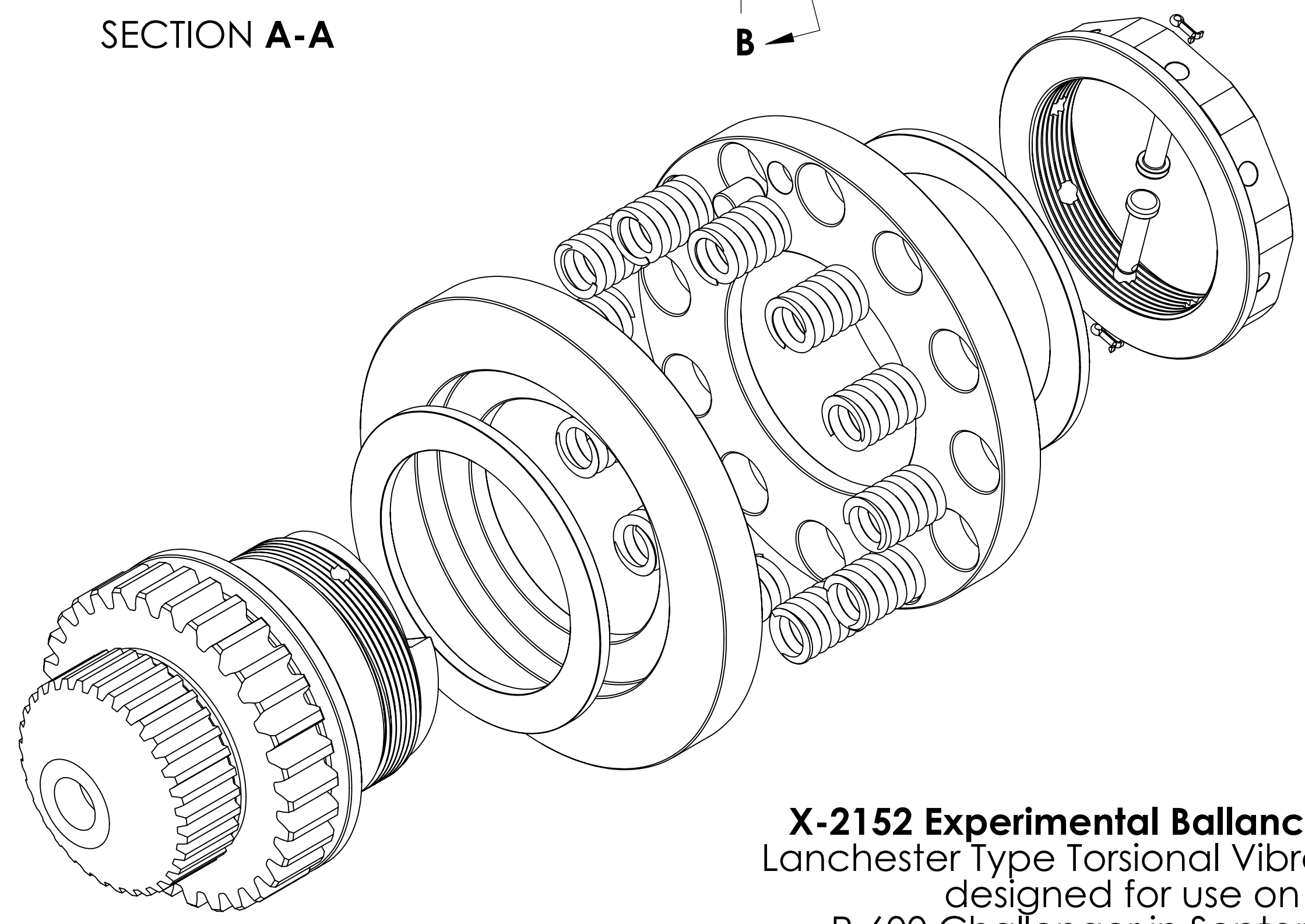
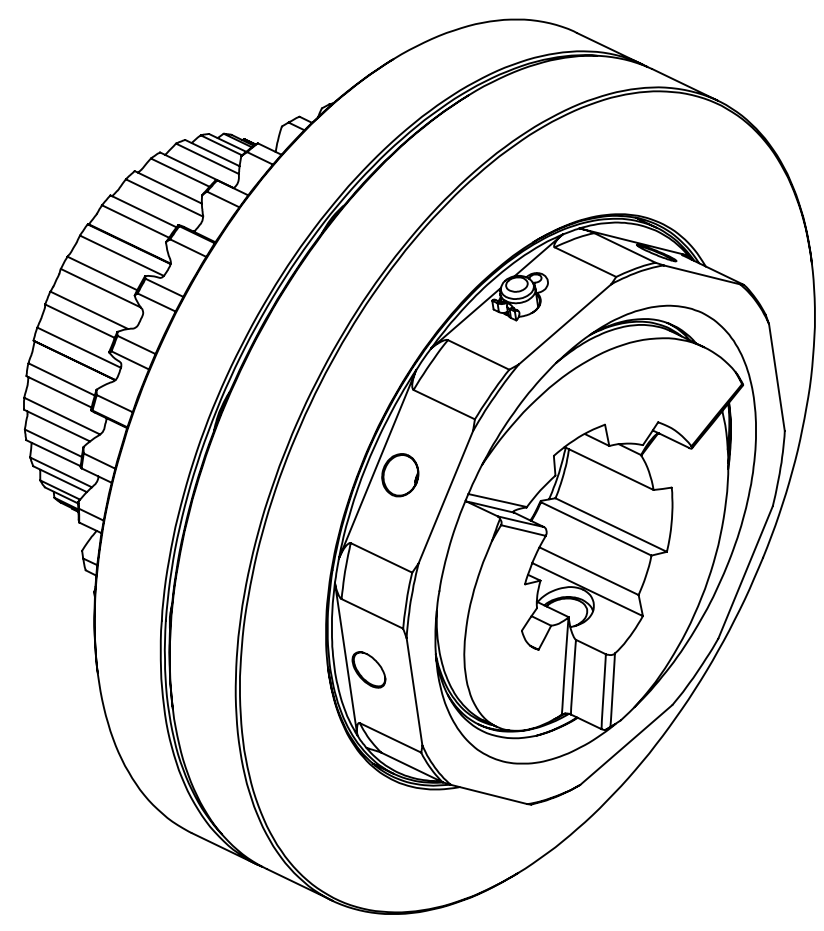

X-2152 Experimental Ballancer Assembly
 Lanchester Type Torsional Vibration Damper
 designed for use on the
 R-600 Challenger in September 1929
 J Riend 18sep22

NOTE:
 These drawings may be used solely for non-commercial use such as historical research, exhibition, model-making, or for non-profit restoration purposes. Models or restored aircraft must remain inoperable and incapable of flight. Drawings may not be used to restore operable aircraft, or engines, to an airworthy status or building flyable or operable reproductions or restorations.

4

3

2

1