

SECTION A-A

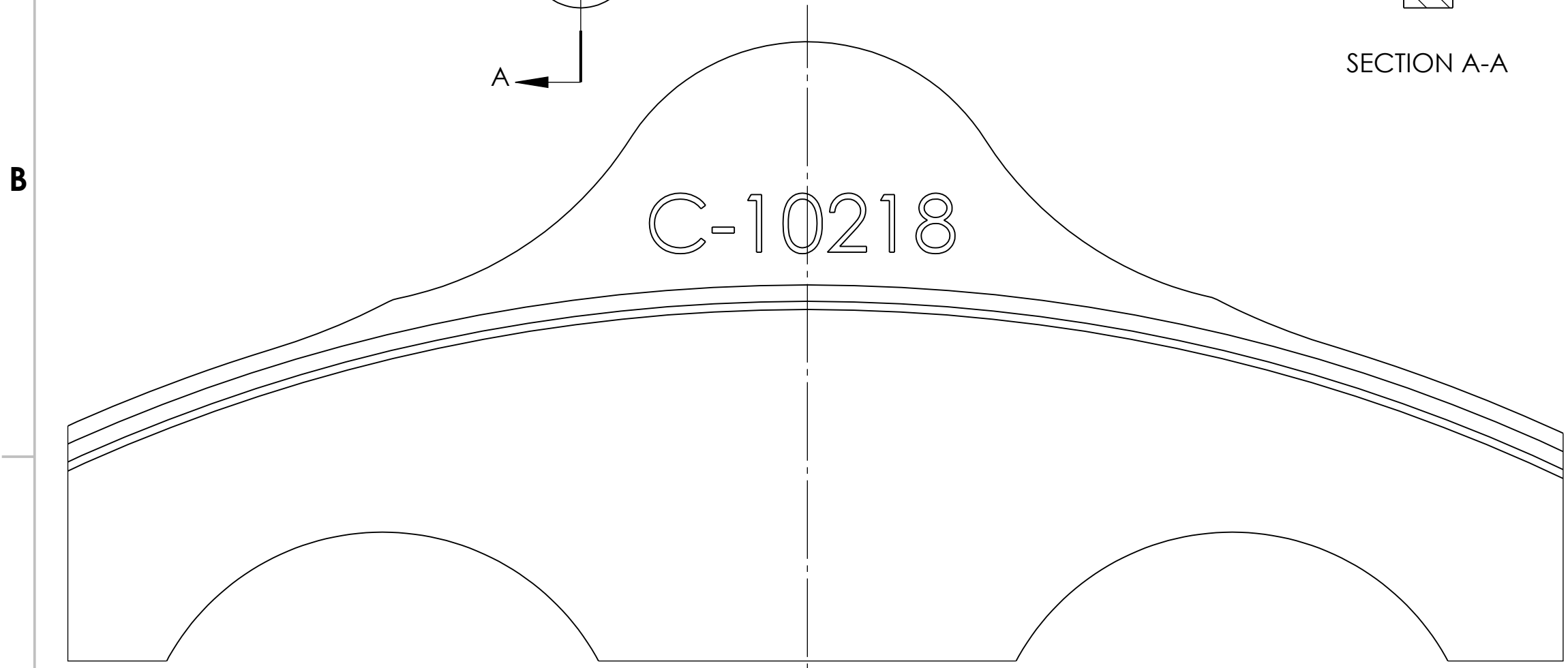

DETAIL C  
SCALE 4 : 1

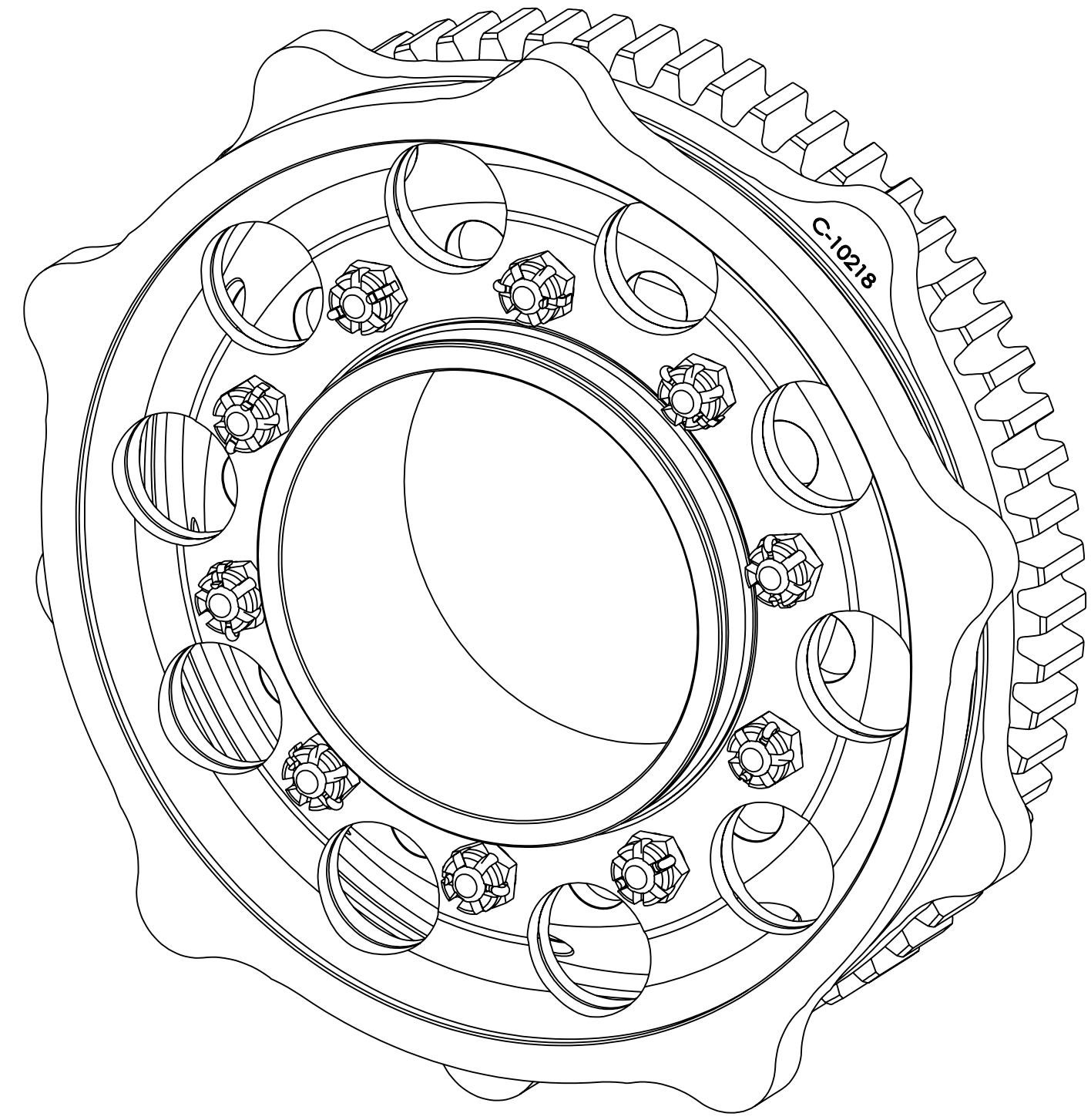

C-10225A Cam Gear Assy Complete (Early).

Three different types of Cams and Valve Tappet Guides were used on Challenger R-600 engines.

The early production types were equipped with concentric valve tappet guides and the Intermediate and Late production types were equipped with eccentric valve tappet guides for the No's. 2, 3, 5 and 6 cylinders.

A complete Late Type Cam and eccentric Valve Tappet Guide kit was available for field installation.

J Riend 25nov22

NOTE:  
These drawings may be used solely for non-commercial use such as historical research, exhibition, model-making, or for non-profit restoration purposes. Models or restored aircraft must remain inoperable and incapable of flight. Drawings may not be used to restore operable aircraft, or engines, to an airworthy status or building flyable or operable reproductions or restorations.